



ENVMETER-485 Pro configuration

Best Practice Installation Manual

Issue 02
Date 07-03-2023

Index

1.Recommended to do during the installation.....	3
1.1 Mechanical.....	3
1.2 Electrical.....	4
1.3 Configuration software/Firmware.....	5
2. Not recommended to do during the installation.....	7
3. MODBUS troubleshooting.....	8
4.Contact and Customer support.....	11

About This Document

Purpose

This document introduces the best installation practices for the configuration set up of Soluzione Solare sensor – ENVMETER-485 PRO by briefly mentioning the recommended and not recommended practices during the field installation. This document also gives clear instructions related to troubleshooting of MODBUS 485 configurations.



Intended Audience

This document is intended for consumers of Soluzione Solare sensors and qualified electricians.

1. Recommended to do during the installation

1.1 Mechanical

- (1) In order to get the right fit of male and female side of the connector pin, turn the male side of the connector less than 360° for finding the right position.



- (2) After finding the right position, tighten the connection only by rotating the steel ring and make sure you do not rotate the connector.
- (3) It is best recommended to just place it in a shaded area that is sheltered from rainfall.
- (4) The recommended standard height above ground for ENVMETER Pro is 1.5 meters. It need to be installed in an area that is open and level, ideally in a height above grass or plants for proper ventilation.

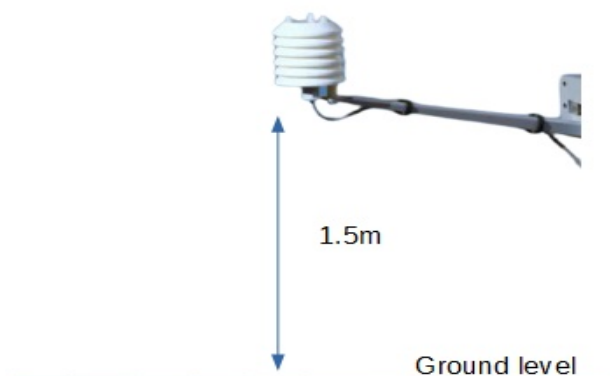

1.2 Electrical

- (1) For proper cable connections, please refer to the instruction manual that comes along with the ENVMETER-485 Pro device and also you can find it in this following link:

(https://www.soluzionesolare.com/documenti/Datasheet_ENVMETER_PRO_485_eng.pdf)

 <i>Frontal view of the output connector</i>	<i>PIN # (1m)</i>	<i>Wire colour (4m)</i>	<i>Description</i>
	1	Green	RS485+/B
	2	Red	V+
	3	Green/White	RS485-/A
	4	Black	V-

- (2) Power supply should be connected with the exact pins as the manual indicates and the suitable voltage to be supplied is 7,5-28 Vdc.
- (3) For the connections, we suggest you to use twisted cables which are shielded.
- (4) Always connect the shield to the ground.
- (5) If there is no signal received from the RS485 port, try to swap the cables A and B and check again if the signal is received.

1.3 Configuration software/Firmware

- (1) For the first time after unboxing the ENVMETER-485 Pro, connect it using the default settings (Address = 1, Baud rate =19200 and Serial configuration = 8N1).

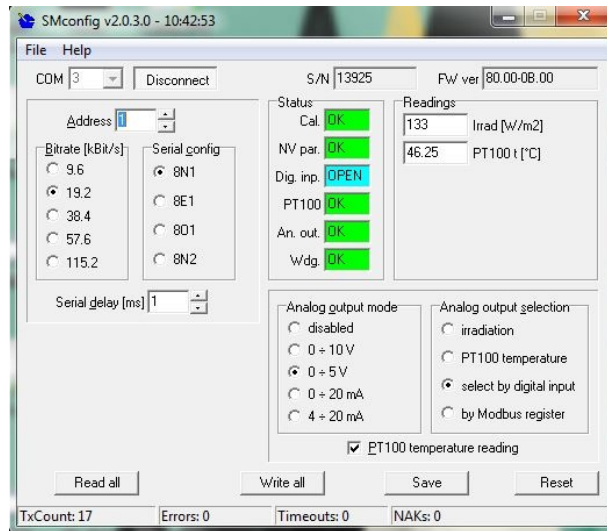

- (2) After turning on the ENVMETER-485 Pro, please wait for 5 seconds before connecting it to the SM config software in order to achieve a proper configuration.
- (3) In case, if you need to change the default settings value, use the SM config software by first connecting the device with the default setting values mentioned in point 1 and then change them to the required values.
- (4) After changing the values click these buttons in the sequence as mentioned 1) Read all 2) Write all 3) Save and 4) Reset

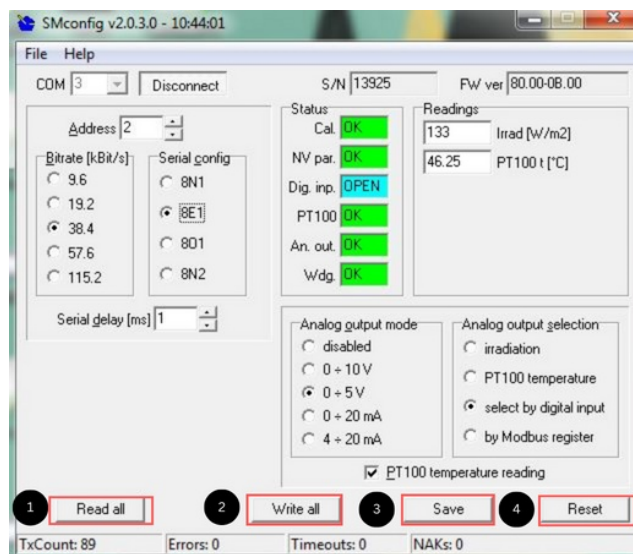

- (5) Please ensure you leave a time gap of 2 seconds in between clicking each buttons.
- (6) We recommend you to place a label on the ENVMETER-485 Pro with the new settings in order to remember the modified new settings.
- (7) Bit rate should be set low in case of long wire connections and environment with more electrical noises.

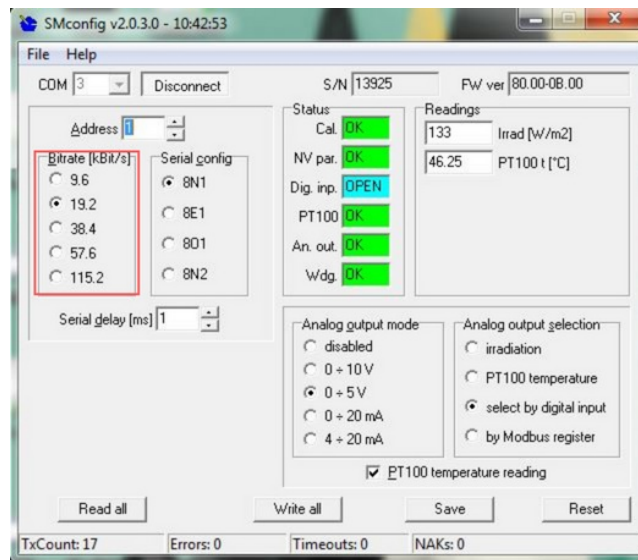

2. Not recommended to do during the installation

1. It is not recommended to place that sensor in an area where the sun's rays strike it directly. It is best to just place it in a shaded area that is sheltered from rainfall.

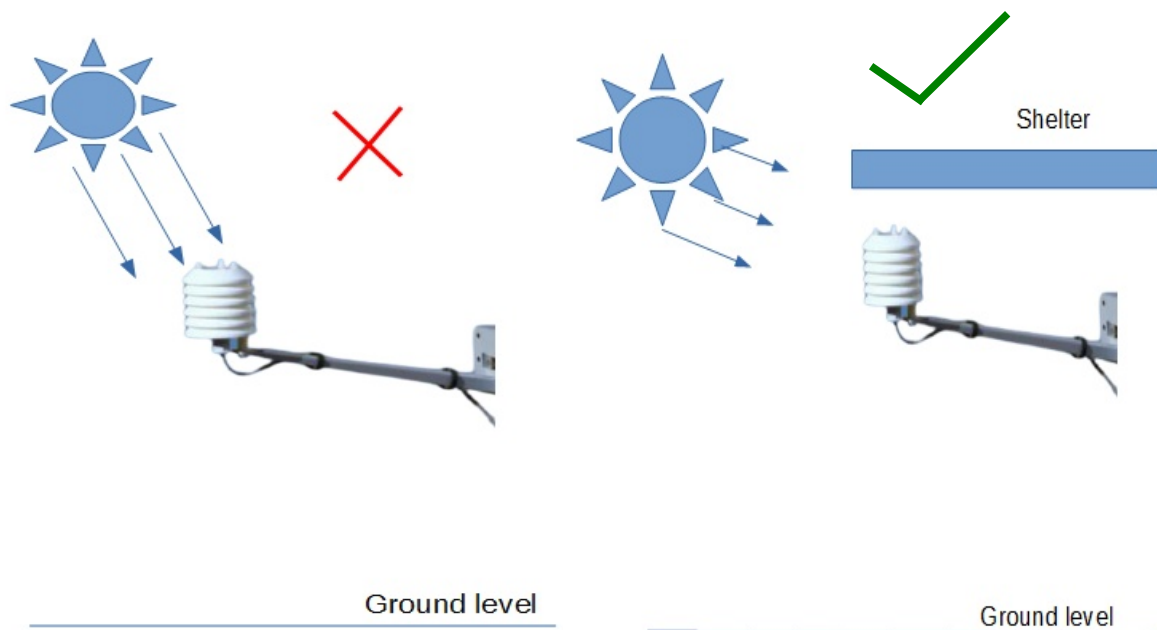

2. Do not place the sensor in rocky terrain, dusty environment or dirt.
3. Do not place the sensor on a steep slope because of the effect gravity affects water and air flow rate.
4. Avoid presence of heating and cooling sources as well as nearby obstructions in order achieve optimal readings.
5. Avoid areas where water residue collects or pools.
6. DO NOT Install your sensor under a tree or any kind of vegetation or plants which causes deviated measurements.
7. Do not bend the connectors or cables and it is not recommended to place it on sharp edges which could cause physical damages.
8. It is not recommended to use dusty sensors which could show a deviated readings. Always clean the sensors to ensure optimal readings.

3.MODBUS troubleshooting

Important Note !!

In General, Dataloggers and Soluzione Solare sensor devices comes with lines which are polarized by default. **Only incase** if you face any problem with the MODBUS communication please refer to the steps given below.

(3.1) For troubleshooting and information about MODBUS protocol kindly visit <https://modbus.org/> even for recommendations on polarization. Kindly check the general schema of the MODBUS RS485 protocol given below.

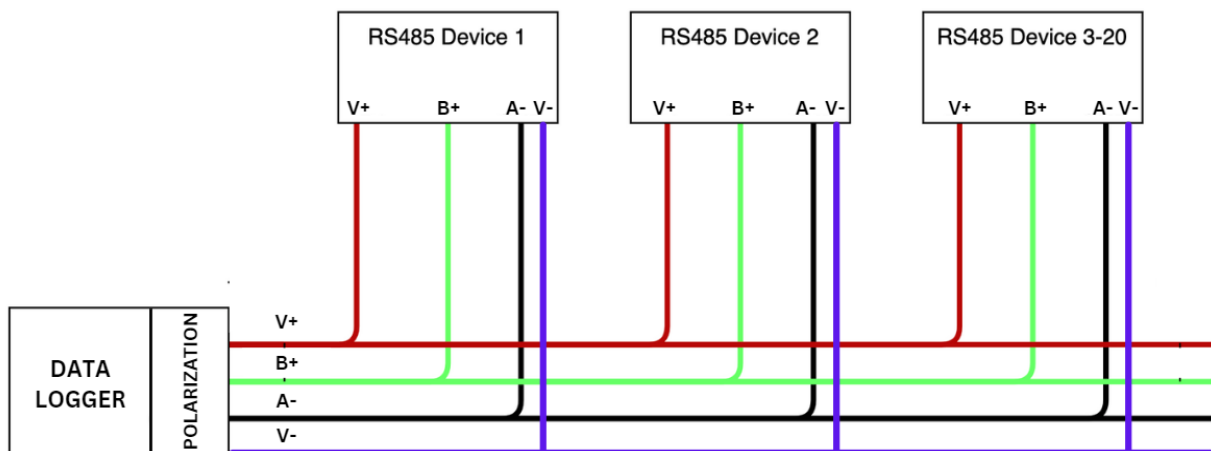

(3.2) In case if you have a bad communication and in order to have a right polarization, follow this formula for calculating the voltages between B+ and A- for finding out if the connections satisfy the condition

$$V_{B+} - V_{A-} \geq 0.2 \text{ V}$$

Polarization network

If the above condition is not satisfied, please refer to the polarization network to be inserted on the bus

$$\text{B+ potential value: } V_{B^+} = \frac{(R_2 + R_3)V^+}{(R_1 + R_2 + R_3)}$$

$$\text{A- potential value: } V_{A^-} = \frac{(R_3)V^+}{(R_1 + R_2 + R_3)}$$

Where R_1 , R_2 and R_3 are the three resistors.(refer to the example images)

V^+ is the supply voltage

If the Datalogger does not have this RS485 polarization net, the user has to do the proxy from input/output.

If the lines are longer user could implement the polarization and if the line is more longer it is suggested to provide with a local power supply which should be polarized.

Examples of local power supply for less than 5 devices connected is given below.

Example for 12V

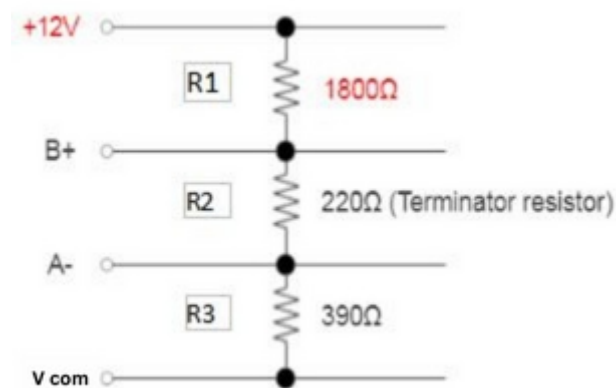

Example for 24V

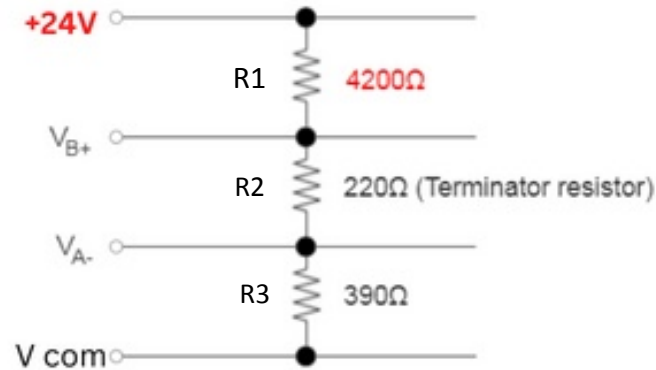

Note

Terminator resistor is required for **high speed and longer lines**, except in the use of dataloggers like Huawei, Sungrow, Goodwe.. etc which **does not** require the terminator resistor even in those above mentioned conditions.

(3.3) If you have troubles with MODBUS connection which can happen if you have more than a couple of devices from different manufacturers connected in the same RS485 line, it is suggested to test the values along the RS485 cable. If you find it difficult to test the values along the line, MODBUS test box can be used. Please check the output voltage levels and impedance of each terminal using the MODBUS test box.

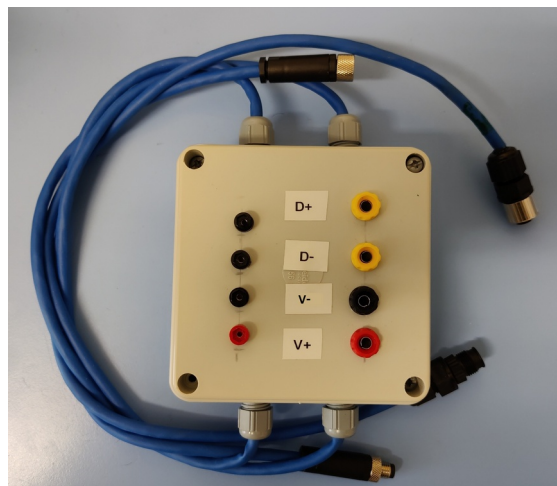

Contact and Customer support

Soluzione Solare S.r.l.

Email: tecnico@soluzionesolare.it

Phone: +39 0444 530234



In case of technical support,

In the email please include the below mentioned information:

- Mention the Device model
- Mention the Device serial number
- Mention the information about the fault or problem
- Attach some pictures which represents the fault or problem